



Emerson Power Transmission  
 P. O. Box 687  
 Maysville, KY 41056  
 Phone: 800-626-2093  
 www.emerson-ept.com

**F O R M**  
**8865**  
**Revised**  
**January 2008**

# Installation, Operation and Maintenance Instructions For Right Angle Syncrogear®

for your safety, read and retain this manual.

### Safety First

High voltage and rotating parts can cause serious or fatal injury. Safe installation, operation and maintenance must be performed by qualified personnel. Familiarization with and adherence to NEMA MG2, the National Electrical Code and local codes is recommended. It is important to observe safety precautions to protect personnel from possible injury. Personnel should be instructed to:

1. Avoid contact with energized circuits or rotating parts.
2. Disconnect all power sources before initiating any maintenance or repair.
3. Act with care in accordance with prescribed procedures in handling and lifting this equipment.
4. Be sure unit is electrically grounded in accordance with code requirements.
5. Be sure equipment is properly enclosed to prevent access by children or other unauthorized personnel in order to prevent possible accidents.
6. Be sure shaft key is fully captive before unit is energized.
7. Avoid contact with capacitors until safe discharge procedures have been completed.
8. Provide proper safeguards for personnel against rotating parts and applications involving high inertia loads which can cause overspeed.
9. Avoid extended exposure to equipment with high noise levels.
10. Be familiar with the equipment and read all instructions thoroughly before installing or working on equipment.

### Inspection and Handling

Inspect unit to make sure no damage has occurred during shipment.

**▲WARNING** Units should be lifted using all eyebolts or lugs, if provided. These eyebolts or lifting lugs are for lifting this unit only and must not be used to lift any additional weight. Use only approved eyebolts and lifting techniques. Failure to observe this warning may result in serious personal injury.

### Storage and Mounting

Units should be stored in a clean, dry location. If units are to be stored for over six months, refer to Emerson Power Transmission.

Mount units to a firm, flat surface which is sufficiently rigid to prevent vibration. Drive belts and chains should be within recommended limits of tightness. Couplings should be properly aligned and balanced. For drive recommendations refer to drive or equipment manufacturer or to Emerson Power Transmission.

**▲WARNING** Guards should be provided for all exposed rotating parts to prevent possible personal injury. Keep fingers and foreign objects away from ventilation and other openings. Applications involving high inertia loads may damage this equipment due to motor overspeed during shut down. Such applications should be referred to Emerson Power Transmission.

**▲CAUTION** Do not force drive coupling or other equipment onto shaft, as bearing damage may result.

	<b>▲WARNING</b>	
	<p>High voltage and rotating parts may cause serious or fatal injury.</p> <p>Turn off power to install or service.</p> <p>Operate with guards in place.</p> <p>Read and follow all instructions.</p>	



### Lubrication

The normal operating temperature of a worm gear reducer may be as high as 200°F. During initial break-in higher temperatures may occur. If the temperature exceeds 200°F for longer than 100 hours consult the factory.

1. Install the breather (vent plug) supplied, in correct location see diagrams on the back of this card. Adjust the oil level if mounting other than in "Worm Top" position. The unit is shipped from Emerson Power Transmission with AGMA #8C oil.
2. Change initial oil fill after 500 hours or 5 weeks.
3. Change oil every 2500 hours service or 6 months. If severe operating conditions exist, change oil every 1 to 3 months.
4. 90 weight oil and EP oil are not recommended.
5. For ambient temperatures -25°F to 15°F use a synthetic lubricant. (See table on reverse). Recommended synthetic oils are acceptable for ambient temperatures up to 125°F. When changing oil type, the unit should be carefully drained and flushed prior to re-filling.
6. For units running at slow speeds or under other unusual conditions, contact Emerson Power Transmission.

### Lubricants / Manufacturers

The companies and oils shown below are typical. Any make of oil meeting American Gear Manufacturers Association (AGMA) standards #7C and #8C will be satisfactory.

#### Synthetic Lubricants

Ambient Temp.	Manufacturer	Synthetic oil
-25° to 125° F	Mobil®	SHC 634
	Shell®	Omala® RL 460 Omala RL 680

#### Mineral Oils

Ambient Temp	15°F to 60°F	50°F to 125°F
Viscosity Range (cSt at 40°C)	414 - 506	612 - 748
ISO Grade	460	680
AGMA Grade	#7C	#8C
Shell	Valvata® Oil J460	Valvata Oil J680
Mobil	600 Super Cyl. Oil	Extra Hecla Super Cyl. Oil

The trade names, trademarks and/or registered trademarks that follow are used in this material by Emerson Power Transmission Corporation for comparison purposes, are NOT owned or controlled by Emerson Power Transmission Corporation and are believed to be owned by the parties identified: Shell, Valvata and Omala: Shell Petroleum Incorporated; Mobil: Exxonmobil Oil Corporation.

Emerson Power Transmission Corporation cannot and does not represent or warrant the accuracy of this information.



**1 GWO, GWP**

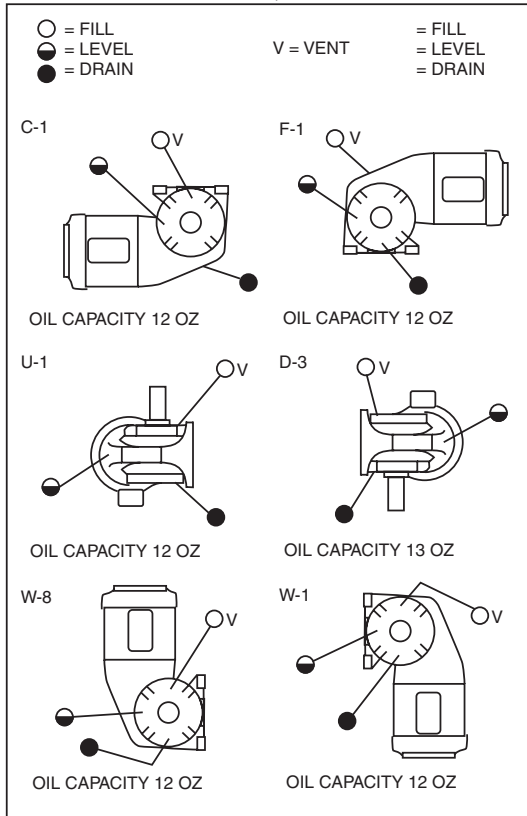

**6 & 20 GW, GWP**

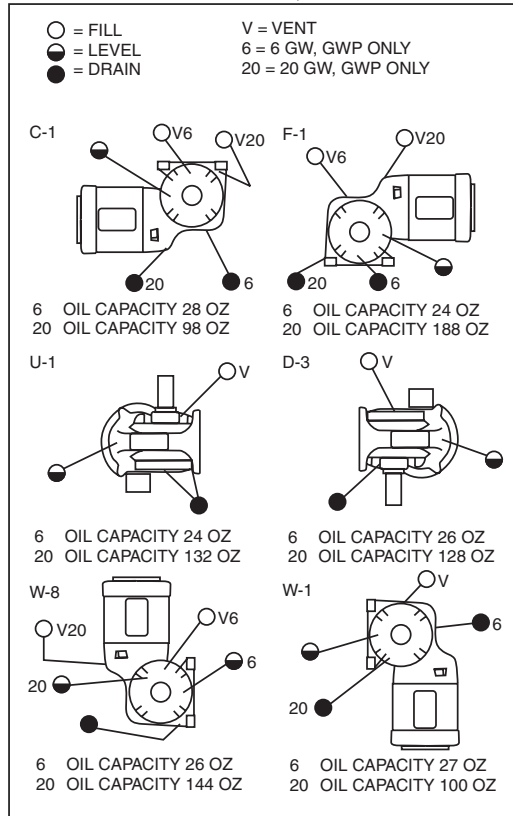

**6 & 20 GWV, GWVP**

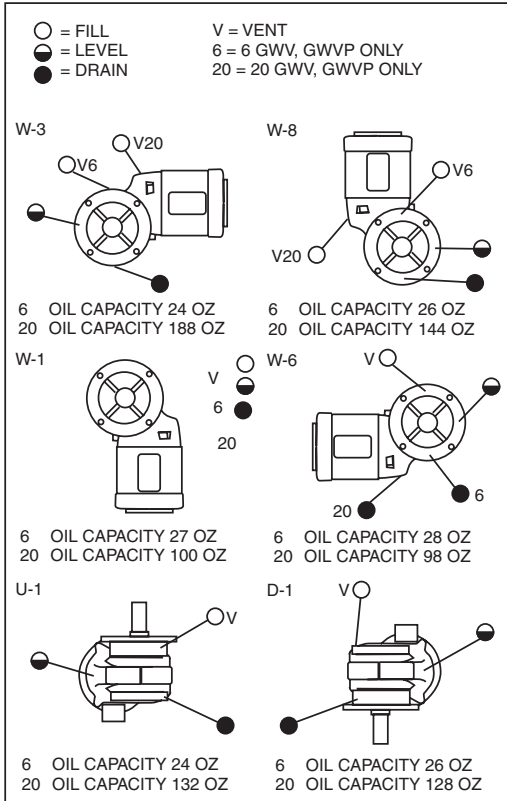

**6 GWB, GWBP**

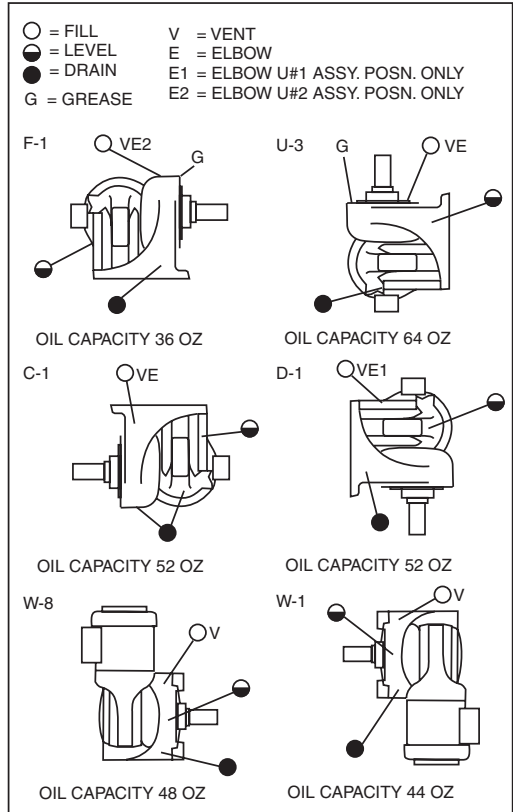

**WARNING** Disconnect all power before adjusting units.

**Warranty Service**

For Warranty Service call:  
Emerson Power Transmission  
Maysville, KY 41056  
Phone (800) 626-2093 Fax (606) 564-2079  
Give complete nameplate data,  
including identification number.