

BALDOR[®] MOTORS AND DRIVES

Three Phase Line and Load Reactors



1920

...in the beginning....Baldor begins operations in St. Louis, MO.



1952



Baldor ships first "adjustable speed motor system"

1983



Baldor enters the world of servos (acquires Munich, Germany, and Minnesota facilities)

1990



Baldor introduces Series 11 inverter controls

1991



Baldor expands into Vector controls with the acquisition of Sweo Controls

1992

Baldor introduces BSM servo motor family



Baldor has been leading the way in energy efficient industrial motors since the 1920's, has been supplying the industry with adjustable speed controls since 1952, and has been supplying servos and motion control products since 1983.

Since then, products have been introduced and expanded to include:

- AC & DC servos, vector and induction servos
- Easy to use keypad-operated or Windows™-based controls
- Autotuning
- Multi-axis controls
- Fully programmable motion controllers
- PCI & PC bus motion controllers

Technical sales and service is available from Baldor's world wide distribution network.

Baldor maintains an extensive stock of these products for immediate shipment.

1994

Baldor introduces multi-axis controls



2000

Baldor opens new engineering and manufacturing center in Bristol, England



1999

Baldor introduces new family of Servo and Motion Controls



1998



Baldor expands Bus Communication Capabilities

1997

Baldor expands programmable motion capability with the acquisition of Optimised Controls in Bristol, England



1997



Baldor expands servo motor facility Westville, OK

1996

Addition of Induction Servo



Three Phase Line Reactors

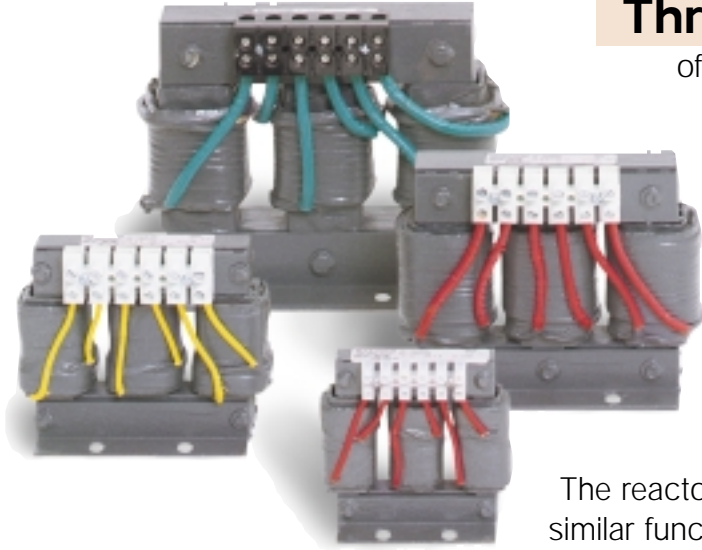

offer an easy and economical solution to a variety of application considerations associated with adjustable speed drive installations. Properly sized reactors can be used to solve or eliminate problems on the input or the output of the motor control. All Baldor three phase reactors are designed with harmonic compensation and rugged construction to provide the extra operating margin you've come to expect from Baldor products.

The reactor acts as a current limiting device and performs a similar function to the familiar DC Choke. The reactor will act as a filter to the power waveform to attenuate electrical noise and unwanted harmonics. When used on the input of a motor control a reduction of over voltage trips and harmonics can be seen. When applied on the output of a motor control, a smoothing of the power waveform to the motor can increase motor efficiency and operating life.

All Baldor three phase reactors can be used on the line power side as a "line reactor" or on the load side of a motor control as a "load reactor". In either case, you can have confidence that you'll get great performance and value from Baldor.

Application and Sizing

Reactors are current rated devices and therefore have an associated impedance value. Impedance is seen as a resistance to current flow. The higher the impedance, the more resistance the reactor will supply to keep the current through the reactor at a constant level. To size a reactor, the total continuous current (full load amps) supplied through the reactor and the impedance desired for the application will need to be determined. For single motor applications, the current will be the nominal continuous operating current or the motor rated current, whichever is lower. For multiple motor applications the current will be the sum of all the nominal continuous operating currents supplied through the reactor. As the following relationship shows, the supplied impedance of a given reactor is reduced as the load current is reduced:

$$\% \text{ Impedance} = \frac{\mathbf{I}_{\text{CONT}} \times 2\pi \times f \times L \times \sqrt{3}}{V_{\text{LL}}} \times 100$$

- Where: \mathbf{I}_{CONT} = Continuous current through the reactor in Amps RMS
 f = Frequency of the AC waveform applied to the reactor
 V_{LL} = Line to Line Voltage (Phase to Phase) applied to the reactor
 L = Inductance of the reactor windings in milli-henrys

Size on Actual Input Conditions

Verify the reactor supplies desired impedance at actual load current, voltage and line frequency. Notice in the percent impedance relationship, if the line voltage is higher than the reactor rating voltage, the effective impedance will be lower. Similarly, if the load current through the reactor is lower than the reactor rating current, the effective impedance will be lower. Some motor controls will specify a minimum line impedance value to protect the controls power conversion devices. Care should be used in selecting line side reactors that are used to increase the line impedance to provide necessary minimum impedance. Baldor reactors are designed to provide the minimum impedance requirements when used in over-voltage and under-current applications.

Size for Voltage Reduction and Transients

Motor controls that have a relatively low over-voltage threshold will benefit from the use of line side reactors. With today's increased energy demands some utilities are increasing the nominal transmission voltages to provide slightly more power to users without having to generate more energy. As the line voltage creeps up, the instances of over-voltage faults can increase on motor controls.

Line side reactors will reduce the voltage applied to a motor control by the amount of % impedance. For example, a 3% reactor will reduce a 490 Volt AC line to 475 Volts at the motor control terminals. The voltage reduction will effectively increase the voltage margin available before an over-voltage trip can occur on modern motor controls.

Power lines are subjected to voltage distortion that can occur as a result of utility switching or thunderstorms and lightning. The inductive property of a line side reactor provides a smoothing of voltage transients that occur on power lines. The voltage

reduction properties coupled with the reactors ability to smooth out voltage transients helps to reduce the instances of motor control faults, which will increase the operating time and effectiveness of your equipment.

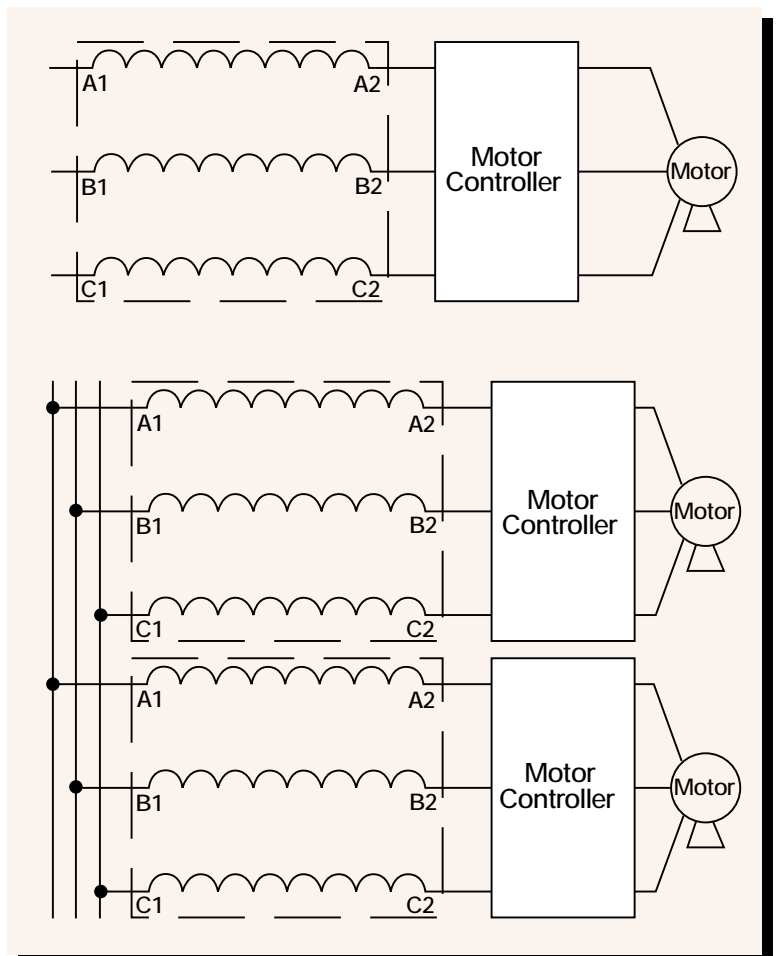

Size For Motor Protection

Baldor reactors can also be used on the load side of motor controls to provide additional protection to three phase motors. Modern fast switching motor controls can produce transients that may result in elevated voltages at the terminals of motors. Load reactors can be applied to reduce the transients resulting in increased motor efficiency and operating life. The additional impedance of the load reactor also limits the rate of rise of short circuit currents available to the motor windings to help prevent premature failures during periods of motor overloading. In most cases the load reactor should be placed as close to the motor control as possible.

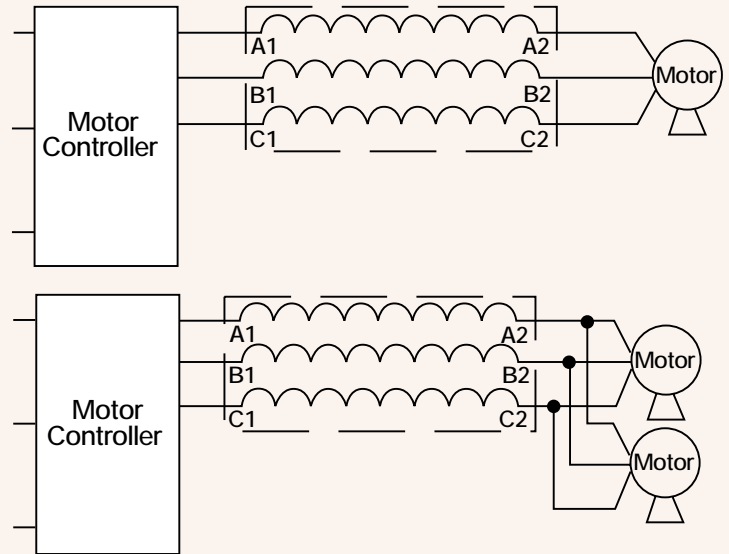

Multiple motor applications can also benefit from the use of load reactors. A single reactor can be sized to permit the total current draw of all the motors connected to the motor control. To provide maximum protection to the motor windings, one reactor per motor should be considered in shared controller applications. In both cases the reactor should be located as close to the motor control as possible.

Optional Protective Enclosures

Baldor offers a complete line of enclosures to provide NEMA 1 protection to line or load reactors. Smaller reactors can be wall mounted while larger and heavier reactors should be floor mounted.

REACTOR ENCLOSURES

Enclosure Catalog No.	To Fit LRAC Catalog No.	Mounting Type	Weight (lbs)	Dimensions (In)		
				Height	Width	Depth
LRENC-8	LRAC002-4XX, LRAC008-12XX LRAC01801, LRAC01802	Wall	7	10	8	6
LRENC-13	LRAC01803, LRAC025-35XX LRAC045-80XX	Floor	34	15	13	13
LRENC-15	LRAC110-200XTB LRAC100-160XX	Floor	45	16	15	13
LRENC-20S	LRAC200-500XX, LRAC250-950ACB	Floor	50	19	20	20

200-240 VOLT INPUT, 50 HERTZ, 3% IMPEDANCE

HP	KW	Input Volts	Catalog No.	Input Amp	Inductance	Watts Loss	Weight (lbs)	Dimensions (In)			Terminal	Optional Enclosure
								Height	Width	Depth		
1	0.75	200-240	LRAC00401	4A	3.0mH	14.5	4	4	4.4	2.9	Screw	LRENC-8
2	1.5	200-240	LRAC00801	8A	1.5mH	19.5	7	4.8	6	3.1	Screw	LRENC-8
3	2.2	200-240	LRAC01201	12A	1.25mH	26	9	4.8	6	3.1	Screw	LRENC-8
5	3.7	200-240	LRAC01801	18A	0.8mH	36	9	4.8	6	3.1	Screw	LRENC-8
7.5	5.5	200-240	LRAC02501	25A	0.5mH	48	11	5.6	7.2	3.4	Screw	LRENC-13
10	7.5	200-240	LRAC03501	35A	0.4mH	49	14	5.6	7.2	3.8	Screw	LRENC-13
15	11.1	200	LRAC04501	45A	0.3mH	54	23	7	9	4.8	Screw	LRENC-13
20	14.9	200	LRAC05501	55A	0.25mH	64	24	7	9	4.8	Screw	LRENC-13
25	18.6	200	LRAC080BTB	80A	0.138mH	105	23	6.89	8.12	4.25	Screw	LRENC-15
30	22.3	200	LRAC110BCB	110A	0.1mH	95	26	6.89	8.88	4.25	Bus Bar	LRENC-15
40	29.8	200	LRAC130BCB	130A	0.085mH	117	33	8.5	9.88	4.75	Bus Bar	LRENC-15
50	37.2	200	LRAC160BCB	160A	0.069mH	127	47	9.5	10.56	8.25	Bus Bar	LRENC-15

208-230 VOLT INPUT, 60 HERTZ, 3% IMPEDANCE

HP	KW	Input Volts	Catalog No.	Input Amp	Inductance	Watts Loss	Weight (lbs)	Dimensions (In)			Terminal	Optional Enclosure
								Height	Width	Depth		
1	0.75	208/230	LRAC00401	4A	3.0mH	14.5	4	4	4.4	2.9	Screw	LRENC-8
1.5-2	1.1-1.5	208/230	LRAC00801	8A	1.5mH	19.5	7	4.8	6	3.1	Screw	LRENC-8
3	2.2	208/230	LRAC01201	12A	1.25mH	26	9	4.8	6	3.1	Screw	LRENC-8
5	3.7	208/230	LRAC01801	18A	0.8mH	36	9	4.8	6	3.1	Screw	LRENC-8
7.5	5.5	208/230	LRAC02501	25A	0.5mH	48	11	5.6	7.2	3.4	Screw	LRENC-13
10	7.4	208/230	LRAC03501	35A	0.4mH	49	14	5.6	7.2	3.8	Screw	LRENC-13
15	11.1	208/230	LRAC04501	45A	0.3mH	54	23	7	9	4.8	Screw	LRENC-13
20	14.9	208/230	LRAC05501	55A	0.25mH	64	24	7	9	4.8	Screw	LRENC-13
25	18.6	208/230	LRAC080BTB	80A	0.138mH	105	23	6.89	8.12	4.25	Screw	LRENC-15
30	22.3	208/230	LRAC110BCB	110A	0.1mH	95	26	6.89	8.88	4.25	Bus Bar	LRENC-15
40	29.8	208/230	LRAC130BCB	130A	0.085mH	117	33	8.5	9.88	4.75	Bus Bar	LRENC-15
50	37.2	208/230	LRAC160BCB	160A	0.069mH	127	47	9.5	10.56	8.25	Bus Bar	LRENC-15

380/400/415 VOLT INPUT, 50 HERTZ, 3% IMPEDANCE

HP	KW	Input Volts	Catalog No.	Input Amp	Inductance	Watts Loss	Weight (lbs)	Dimensions (In)			Terminal	Optional Enclosure
								Height	Width	Depth		
1	0.75	380	LRAC00201	2A	12.0mH	7.5	4	4	4.4	2.8	Screw	LRENC-8
1	0.75	400/415	LRAC00202	2A	20.0mH	11.3	4	4	4.4	2.9	Screw	LRENC-8
2	1.5	380	LRAC00402	4A	6.5mH	20	4	4	4.4	2.9	Screw	LRENC-8
2	1.5	400/415	LRAC00403	4A	9.0mH	20	5	4	4.4	3.1	Screw	LRENC-8
3	2.2	380/400/415	LRAC00803	8A	5.0mH	25.3	11	4.8	6	3.4	Screw	LRENC-8
5	3.7	380/400/415	LRAC00802	8A	3.0mH	29	8	4.8	6	3.1	Screw	LRENC-8
7.5	5.5	380/400/415	LRAC01202	12A	2.5mH	31	10	4.8	6	3.1	Screw	LRENC-8
10	7.5	380/400/415	LRAC01802	18A	1.5mH	43	12	4.8	6	3.5	Screw	LRENC-8
15	11.1	380/400/415	LRAC02502	25A	1.2mH	52	14	5.6	7.2	3.4	Screw	LRENC-13
20	14.9	380/400/415	LRAC03502	35A	0.8mH	54	16	5.7	7.2	3.8	Screw	LRENC-13
25-30	18.6-22.3	380/400/415	LRAC04502	45A	0.7mH	62	28	7	9	4.8	Screw	LRENC-13
40	29.8	400/415	LRAC05502	55A	0.5mH	67	27	7	9	4.8	Screw	LRENC-13
50	37.2	380/400/415	LRAC08002	80A	0.4mH	220	32	8.25	9	5.3	Screw	LRENC-13
75	56	380/400/415	LRAC110ACB2	110A	0.1mH	140	55	9.5	10.24	8.18	Bus Bar	LRENC-15
100	75	400/415	LRAC130ACB2	130A	0.17mH	150	57	9.5	10.24	8.18	Bus Bar	LRENC-15
100	75	380	LRAC160ACB2	160A	0.13mH	300	55	9.5	10.24	8.18	Bus Bar	LRENC-15
125	93	380/400/415	LRAC200ACB	200A	0.11mH	340	67	9.5	10.24	8.50	Bus Bar	LRENC-15
150	112	380/400	LRAC250ACB	250A	0.088mH	261	91	12.38	13.44	9	Bus Bar	LRENC-20S
200	149	415	LRAC250ACB	250A	0.088mH	261	91	12.38	13.44	9	Bus Bar	LRENC-20S
250	186.5	380/400/415	LRAC360ACB	360A	0.061mH	380	98	12.38	13.44	9	Bus Bar	LRENC-20S
300	223.8	380/400/415	LRAC420ACB	420A	0.053mH	400	100	12.38	13.44	9	Bus Bar	LRENC-20S
350	261	380/400	LRAC480ACB	480A	0.046mH	392	110	12.38	13.44	9	Bus Bar	LRENC-20S
400	298	415	LRAC480ACB	480A	0.046mH	392	110	12.38	13.44	9	Bus Bar	LRENC-20S
500	373	380/400	LRAC600ACB	600A	0.037mH	493	151	12.38	13.44	10.25	Bus Bar	LRENC-20S
600	448	380	LRAC750ACB	750A	0.029mH	515	283	17.25	16.94	10.25	Bus Bar	LRENC-20S
700	522	380/400	LRAC850ACB	850A	0.026mH	569	290	17.25	16.94	10.25	Bus Bar	LRENC-20S
800	597	380/400	LRAC950ACB	950A	0.023mH	686	295	17.25	16.94	10.25	Bus Bar	LRENC-20S

Agency Approvals



Baldor Three Phase AC Reactors are UL and CUL listed. No additional testing will be required when using Baldor Reactors in your UL Listed Control Panels. Contact Baldor for more information on agency approvals.

460 VOLT INPUT, 60 HERTZ, 3% IMPEDANCE

HP	KW	Input Volts	Catalog No.	Input Amp	Inductance	Watts Loss	Weight (lbs)	Dimensions (In)			Terminal	Optional Enclosure
								Height	Width	Depth		
1-1.5	0.75A-1.1	460	LRAC00201	2A	12.0mH	7.5	4	4	4.4	2.8	Screw	RENC-8
2-3.	1.5-2.2	460	LRAC00402	4A	6.5mH	20	4	4	4.4	2.9	Screw	RENC-8
5	3.7	460	LRAC00802	8A	3.0mH	29	8	4.8	6	3.1	Screw	RENC-8
7.5	5.5	460	LRAC01202	12A	2.5mH	31	10	4.8	6	3.1	Screw	RENC-8
10	7.4	460	LRAC01802	18A	1.5mH	43	12	4.8	6	3.5	Screw	RENC-8
15	11.1	460	LRAC02502	25A	1.2mH	52	14	5.6	7.2	3.4	Screw	RENC-13
20-25	14.9-18.6	460	LRAC03502	35A	0.8mH	54	16	5.7	7.2	3.8	Screw	RENC-13
30	22.3	460	LRAC04502	45A	0.7mH	62	28	7	9	4.8	Screw	RENC-13
40	29.8	460	LRAC05502	55A	0.5mH	67	27	7	9	4.8	Screw	RENC-13
50-60	37.2-44.7	460	LRAC08002	80A	0.4mH	220	32	8.25	9	5.3	Screw	RENC-13
75	56	460	LRAC110ACB2	110A	0.2mH	140	55	9.5	10.24	8.18	Bus Bar	RENC-15
100	75	460	LRAC130ACB2	130A	0.17mH	150	57	9.5	10.24	8.18	Bus Bar	RENC-15
125	93.2	460	LRAC160ACB2	160A	0.13mH	300	55	9.5	10.24	5.75	Bus Bar	RENC-15
150	112	460	LRAC200ACB	200A	0.11mH	340	67	9.5	10.24	8.58	Bus Bar	RENC-15
200	149	460	LRAC250ACB	250A	0.088mH	261	91	12.38	13.44	9	Bus Bar	RENC-20S
250	186.5	460	LRAC360ACB	360A	0.061mH	380	98	12.38	13.44	9	Bus Bar	RENC-20S
300	223.8	460	LRAC420ACB	420A	0.053mH	400	100	12.38	13.44	9	Bus Bar	RENC-20S
350-400	261-298	460	LRAC480ACB	480A	0.046mH	392	110	12.38	13.44	9	Bus Bar	RENC-20S
500	373	460	LRAC600ACB	600A	0.037mH	493	151	12.38	13.44	10.25	Bus Bar	RENC-20S
600	448	460	LRAC750ACB	750A	0.029mH	515	283	17.25	16.94	10.25	Bus Bar	RENC-20S
700	522	460	LRAC850ACB	850A	0.026mH	569	290	17.25	16.94	10.25	Bus Bar	RENC-20S
800	597	460	LRAC950ACB	950A	0.023mH	686	295	17.25	16.94	10.25	Bus Bar	RENC-20S

575 VOLT INPUT, 60 HERTZ, 3% IMPEDANCE

HP	KW	Input Volts	Catalog No.	Input Amp	Inductance	Watts Loss	Weight (lbs)	Dimensions (In)			Terminal	Optional Enclosure
								Height	Width	Depth		
1-2.	0.75-1.5	575	LRAC00202	2A	20.0mH	11.3	4	4	4.4	2.9	Screw	RENC-8
3	2.2	575	LRAC00403	4A	9.0mH	20	5	4	4.4	3.1	Screw	RENC-8
5	3.7	575	LRAC00803	8A	5.0mH	25.3	11	4.8	6	3.4	Screw	RENC-8
7.5	5.5	575	LRAC00802	8A	3.0MH	29	8	4.8	6	3.1	Screw	RENC-8
10	7.5	575	LRAC01202	12A	2.5mH	31	10	4.8	6	3.1	Screw	RENC-8
15	11.1	575	LRAC01802	18A	1.5mH	43	12	4.8	6	3.5	Screw	RENC-8
20-25	14.9-18.6	575	LRAC02502	25A	1.2mH	52	14	5.6	7.2	3.4	Screw	RENC-13
30	22.3	575	LRAC03502	35A	0.8mH	54	16	5.7	7.2	3.8	Screw	RENC-13
40	29.8	575	LRAC04502	45A	0.7mH	62	28	7	9	4.8	Screw	RENC-13
50	37.2	575	LRAC05502	55A	0.5mH	67	27	7	9	4.8	Screw	RENC-13
60-75	44.7-56	575	LRAC08002	80A	0.4mH	220	32	8.25	9	5.3	Screw	RENC-13
100	75	575	LRAC110ACB2	110A	0.2mH	140	55	9.5	10.24	8.18	Bus Bar	RENC-15
125	93.2	575	LRAC130ACB2	130A	0.17mH	150	57	9.5	10.24	8.18	Bus Bar	RENC-15
150	112	575	LRAC160ACB2	160A	0.13mH	300	67	9.5	10.24	8.18	Bus Bar	RENC-15

208-230 VOLT INPUT, 60 HERTZ, 5% IMPEDANCE

HP	KW	Input Volts	Catalog No.	Input Amp	Inductance	Watts Loss	Weight (lbs)	Dimensions (In)			Terminal	Optional Enclosure
								Height	Width	Depth		
0.5	0.375	208/230	LRAC00201	2A	12.0mH	7.5	4	4	4.4	2.9	Screw	LENC-8
1	0.75	208/230	LRAC00402	4A	6.5mH	20	4	4	4.4	2.9	Screw	LENC-8
0.75	0.56	208/230	LRAC00403	4A	9.0mH	20	5	4	4.4	3.1	Screw	LENC-8
2	1.5	208/230	LRAC00802	8A	3.0mH	29	8	4.8	6	3.1	Screw	LENC-8
5	3.7	208/230	LRAC01802	18A	1.5mH	43	12	4.8	6	3.5	Screw	LENC-8
7.5	5.5	208/230	LRAC03502	35A	0.8mH	54	16	5.7	7.2	3.8	Screw	LENC-13
10	7.5	208/230	LRAC04502	45A	0.7mH	62	28	7	9	4.8	Screw	LENC-13
25	18.6	208/230	LRAC080ATB	80A	0.276mH	129	33	8.5	10.25	4.75	Screw	LENC-15
30	22.3	208	LRAC110ACB	110A	0.2mH	152	49	9.5	10.56	8.25	Bus Bar	LENC-15
40	29.8	230	LRAC110ACB	110A	0.2mH	152	49	9.5	10.56	8.25	Bus Bar	LENC-15
40	29.8	208/230	LRAC130ACB2	130A	0.17mH	150	57	9.5	10.24	8.18	Bus Bar	LENC-15
50	37.2	208/230	LRAC16002	160A	0.15mH	149	50	8.4	10.8	6	Bus Bar	LENC-15
60	44.7	208/230	LRAC25003	250A	0.15mH	219	140	14	14.4	11.35	Bus Bar	LENC-20S
75	56	208/230	LRAC200ACB	200A	0.11mH	340	67	9.5	10.24	8.58	Bus Bar	LENC-20S
100	75	208/230	LRAC250ACB	250A	0.088mH	261	91	12.38	13.44	9	Bus Bar	LENC-20S
125	93	208/230	LRAC360ACB	360A	0.061mH	380	98	12.38	13.44	9	Bus Bar	LENC-20S
150	112	208/230	LRAC420ACB	420A	0.053mH	400	100	12.38	13.44	9	Bus Bar	LENC-20S
200	149	208/230	LRAC480ACB	480A	0.046mH	392	110	12.38	13.44	9	Bus Bar	LENC-20S
250	186.5	208/230	LRAC600ACB	600A	0.037mH	493	151	12.38	13.44	10.25	Bus Bar	LENC-20S
300	223.8	208/230	LRAC750ACB	750A	0.029mH	515	283	17.25	16.94	10.25	Bus Bar	LENC-20S
350	261	208/230	LRAC850ACB	850A	0.026mH	569	290	17.25	16.94	10.25	Bus Bar	LENC-20S
400	298	208/230	LRAC950ACB	950A	0.023mH	686	295	17.25	16.94	10.25	Bus Bar	LENC-20S

460 VOLT INPUT, 60 HERTZ, 5% IMPEDANCE

HP	KW	Input Volts	Catalog No.	Input Amp	Inductance	Watts Loss	Weight (lbs)	Dimensions (In)			Terminal	Optional Enclosure
								Height	Width	Depth		
1-1.5	0.75-1.1	460	LRAC00201	2A	12.0mH	7.5	4	4	4.4	2.9	Screw	LENC-8
2-3	1.5-2.2	460	LRAC00402	4A	6.5mH	20	4	4	4.4	2.9	Screw	LENC-8
5	3.7	460	LRAC00802	8A	3.0mH	29	8	4.8	6	3.1	Screw	LENC-8
7.5	5.5	460	LRAC01202	12A	3.0mH	31	10	4.8	6	3.1	Screw	LENC-8
10	7.4	460	LRAC01802	18A	1.5mH	43	12	4.8	6	3.5	Screw	LENC-8
15	11.1	460	LRAC02502	25A	1.2mH	52	14	5.6	7.2	3.8	Screw	LENC-13
20-25	14.9-18.6	460	LRAC03502	35A	0.8mH	54	16	5.7	7.2	3.8	Screw	LENC-13
30	22.3	460	LRAC04502	45A	0.7mH	62	28	7	9	4.8	Screw	LENC-13
40	29.8	460	LRAC05502	55A	0.5mH	67	27	7	9	4.8	Screw	LENC-13
50-60	37.2-44.7	460	LRAC08002	80A	0.4mH	220	32	8.25	9	5.3	Screw	LENC-13
60	44.7	460	LRAC080ATB	80A	0.276mH	129	33	8.5	10.25	4.75	Screw	LENC-15
75	56	460	LRAC110ACB2	110A	0.2mH	140	55	9.5	10.24	8.18	Bus Bar	LENC-15
100	75	460	LRAC130ACB2	130A	0.17mH	150	57	9.5	10.24	8.18	Bus Bar	LENC-15
125	93.2	460	LRAC160ACB2	160A	0.13mH	300	55	9.5	10.24	8.18	Bus Bar	LENC-15
150	112	460	LRAC200ACB	200A	0.11mH	340	67	9.5	10.24	8.58	Bus Bar	LENC-20S
200	149	460	LRAC250ACB	250A	0.088mH	261	91	12.38	13.44	9	Bus Bar	LENC-20S
250	186.5	460	LRAC360ACB	360A	0.061mH	380	98	12.38	13.44	9	Bus Bar	LENC-20S
300	223.8	460	LRAC420ACB	420A	0.053mH	400	100	12.38	13.44	9	Bus Bar	LENC-20S
350-400	261-298	460	LRAC480ACB	480A	0.046mH	392	110	12.38	13.44	9	Bus Bar	LENC-20S
500	373	460	LRAC600ACB	600A	0.037mH	493	151	12.38	13.44	10.25	Bus Bar	LENC-20S
600	448	460	LRAC750ACB	750A	0.029mH	515	283	17.25	16.94	10.25	Bus Bar	LENC-20S
700	522	460	LRAC850ACB	850A	0.026mH	569	290	17.25	16.94	10.25	Bus Bar	LENC-20S
800	597	460	LRAC950ACB	950A	0.023mH	686	295	17.25	16.94	10.25	Bus Bar	LENC-20S

575 VOLT INPUT, 60 HERTZ, 5% IMPEDANCE

HP	KW	Input Volts	Catalog No.	Input Amp	Inductance	Watts Loss	Weight (lbs)	Dimensions (In)			Terminal	Optional Enclosure
								Height	Width	Depth		
3	2.2	575	LRAC00404	4A	12.0mH	21	6	4	4.4	3.6	Screw	LENC-8
5	3.7	575	LRAC00804	8A	7.5mH	28	13	4.8	6	3.4	Screw	LENC-8
10	7.5	575	LRAC01203	12A	4.2mH	41	18	4.8	6	3.7	Screw	LENC-8
15	11.1	575	LRAC01803	18A	2.5mH	43	16	5.7	7.2	3.8	Screw	LENC-13
25	18.6	575	LRAC02503	25A	1.8mH	61	18	5.7	7.2	3.8	Screw	LENC-13
40	29.8	575	LRAC04503	45A	3.0mH	65	39	7	9	5.3	Screw	LENC-13
50	37.2	575	LRAC05503	55A	0.85mH	71	41	7	9	5.6	Screw	LENC-13
100	75	575	LRAC10003	100A	0.45mH	108	74	8.4	10.8	6.3	Bus Bar	LENC-15

200-240 VOLT INPUT, 50 HERTZ, 5% IMPEDANCE

HP	KW	Input Volts	Catalog No.	Input Amp	Inductance	Watts Loss	Weight (lbs)	Dimensions (In)			Terminal	Optional Enclosure
								Height	Width	Depth		
0.5	0.375	200-240	LRAC00201	2A	12.0mH	7.5	4	4	4.4	2.9	Screw	LENC-8
0.75	0.56	200-240	LRAC00403	4A	9.0mH	20	5	4	4.4	3.1	Screw	LENC-8
1	0.75	200-240	LRAC00402	4A	6.5mH	20	4	4	4.4	2.9	Screw	LENC-8
5	3.7	240	LRAC01802	18A	3.0mH	43	12	4.8	6	3.5	Screw	LENC-8
7.5	10	240	LRAC02502	25A	1.2mH	52	14	5.6	7.2	3.8	Screw	LENC-13
7.5-10	5.5-7.5	200-240	LRAC03502	35A	0.8mH	54	16	5.7	7.2	3.8	Screw	LENC-13
10	7.5	240	LRAC04502	45A	0.7mH	62	28	7	9	4.8	Screw	LENC-13
20	14.9	200	LRAC080ATB	80A	0.276mH	129	33	8.5	10.25	4.75	Screw	LENC-15
25-30	18.6-22.3	200	LRAC110ACB	110A	0.2mH	152	49	9.5	10.56	8.25	Bus Bar	LENC-15
40-50	29.8-37.2	200-240	LRAC16002	160A	0.15mH	149	50	8.4	10.8	6	Bus Bar	LENC-15
60	44.7	240	LRAC25003	250A	0.15mH	219	140	14	14.4	11.35	Bus Bar	LENC-20S
100-125	75-93	200-240	LRAC360ACB	360A	0.061mH	380	98	12.38	13.44	9	Bus Bar	LENC-20S
150	112	240	LRAC420ACB	420A	0.053mH	400	100	12.38	13.44	9	Bus Bar	LENC-20S
300	223.8	240	LRAC850ACB	850A	0.026mH	569	290	17.25	16.94	10.25	Bus Bar	LENC-20S

200-240 VOLT INPUT, 50 HERTZ, 5% IMPEDANCE

HP	KW	Input Volts	Catalog No.	Input Amp	Inductance	Watts Loss	Weight (lbs)	Dimensions (In)			Terminal	Optional Enclosure
								Height	Width	Depth		
1	0.75	380	LRAC00202	2A	20.0mH	11.3	4	4	4.4	2.9	Screw	LENC-8
2	1.5	380/400	LRAC00404	4A	12.0mH	21	6	4	4.4	3.6	Screw	LENC-8
3	2.2	380	LRAC00803	8A	5.0mH	25.3	11	4.8	6	3.4	Screw	LENC-8
2	1.5	380	LRAC00804	8A	3.0mH	28	13	4.8	6	3.4	Screw	LENC-8
5	3.7	380/400/415	LRAC01203	12A	4.2mH	41	18	4.8	6	3.7	Screw	LENC-8
7.5	5.5	380/400	LRAC01803	18A	2.5mH	43	16	5.7	7.2	3.8	Screw	LENC-13
10	7.5	380	LRAC02503	25A	1.8mH	61	18	5.7	7.2	3.8	Screw	LENC-13
15	11.1	380	LRAC03503	35A	1.2mH	54	30	7	9	4.8	Screw	LENC-13
20	14.9	400/415	LRAC04503	45A	1.2mH	65	39	7	9	5.3	Screw	LENC-13
25	18.6	380	LRAC05503	55A	0.85mH	71	41	7	9	5.6	Screw	LENC-13
30	22.3	400/415	LRAC05503	55A	0.85mH	71	41	7	9	5.6	Screw	LENC-13
50	37.2	380/400/415	LRAC10003	100A	0.45mH	108	74	8.4	10.8	6.3	Bus Bar	LENC-15
75	56	400/415	LRAC13003	130A	0.3mH	128	64	8.4	10.8	7.25	Bus Bar	LENC-15
125	93.2	415	LRAC16003	160A	0.23mH	138	67	8.4	10.8	7.13	Bus Bar	LENC-15
200	149	415	LRAC32003	320A	0.125mH	351	190	14	14.4	13	Bus Bar	LENC-20S
250	186.5	415	LRAC40003	400A	0.105mH	293	200	14	15.5	14.5	Bus Bar	LENC-20S
300	223.8	400/415	LRAC50003	500A	0.085mH	422	290	14	15.5	14.75	Bus Bar	LENC-20S

REACTOR SPECIFICATIONS

Catalog Number	Rated Amp	Inductance	Watts Loss	Weight lbs. / kg	Dimensions			Terminal	Optional Enclosure
					Height in. / mm	Width in. / mm	Depth in. / mm		
LRAC00201	2A	12.0mH	7.5	4 2	4 102	4.4 112	2.8 71	Screw	LRENC-8
LRAC00202	2A	20.0mH	11.3	4 2	4 102	4.4 112	2.9 74	Screw	LRENC-8
LRAC00401	4A	3.0mH	14.5	4 2	4 102	4.4 112	2.9 74	Screw	LRENC-8
LRAC00402	4A	6.5mH	20	4 2	4 102	4.4 112	2.9 74	Screw	LRENC-8
LRAC00403	4A	9.0mH	20	5 2	4 102	4.4 112	3.1 79	Screw	LRENC-8
LRAC00404	4A	12.0mH	21	6 3	4 102	4.4 112	3.6 91	Screw	LRENC-8
LRAC00801	8A	1.5MH	19.5	7 3	4.8 122	6 152	3.1 79	Screw	LRENC-8
LRAC00802	8A	3.0MH	29	8 4	4.8 122	6 152	3.1 79	Screw	LRENC-8
LRAC00803	8A	5.0mH	25.3	11 5	4.8 122	6 152	3.4 86	Screw	LRENC-8
LRAC00804	8A	7.5mH	28	13 6	4.8 122	6 152	3.4 86	Screw	LRENC-8
LRAC01201	12A	1.25mH	26	9 4	4.8 122	6 152	3.1 79	Screw	LRENC-8
LRAC01202	12A	2.5mH	31	10 4	4.8 122	6 152	3.1 79	Screw	LRENC-8
LRAC01203	12A	4.2mH	41	18 8	4.8 122	6 152	3.7 94	Screw	LRENC-8
LRAC01801	18A	0.8mH	36	9 4	4.8 122	6 152	3.1 79	Screw	LRENC-8
LRAC01802	18A	1.5mH	43	12 5	4.8 122	6 152	3.4 89	Screw	LRENC-8
LRAC01803	18A	2.5mH	43	16 7	5.7 145	7.2 183	3.8 97	Screw	LRENC-13
LRAC02501	25A	0.5mH	48	11 5	5.6 142	7.2 183	3.4 86	Screw	LRENC-13
LRAC02502	25A	1.2mH	52	14 6	5.6 142	7.2 183	3.4 86	Screw	LRENC-13
LRAC02503	25A	2.0mH	61	18 8	5.7 145	7.2 183	3.8 97	Screw	LRENC-13
LRAC03501	35A	0.4mH	49	14 6	5.6 142	7.2 183	3.8 97	Screw	LRENC-13
LRAC03502	35A	0.8mH	54	16 7	5.7 145	7.2 183	3.8 97	Screw	LRENC-13
LRAC03503	35A	1.2mH	54	30 13	7 178	9 229	4.8 122	Screw	LRENC-13
LRAC04501	45A	0.3mH	54	23 10	7 178	9 229	4.8 122	Screw	LRENC-13
LRAC04502	45A	0.7mH	62	28 13	7 178	9 229	4.8 122	Screw	LRENC-13
LRAC04503	45A	1.2mH	65	39 17	7 178	9 229	5.3 135	Screw	LRENC-13
LRAC05501	55A	0.25mH	64	24 11	7 178	9 229	4.8 122	Screw	LRENC-13
LRAC05502	55A	0.5mH	67	27 12	7 178	9 229	4.8 122	Screw	LRENC-13
LRAC05503	55A	0.85mH	71	41 18	7 178	9 229	5.6 142	Screw	LRENC-13
LRAC08002	80A	0.4mH	220	32 14	8.25 210	9 229	5.3 135	Screw	LRENC-13
LRAC080BTB	80A	0.138mH	105	23 10	6.89 175	8.12 206	4.25 108	Screw	LRENC-15
LRAC10003	100A	0.45mH	108	74 33	8.4 213	10.8 274	6.3 160	Bus Bar	LRENC-15
LRAC110ACB2	110A	0.2mH	140	55 25	9.5 241	10.24 260	8.18 208	Bus Bar	LRENC-15
LRAC110BCB	110A	0.1mH	95	26 12	6.89 175	8.88 226	4.25 108	Bus Bar	LRENC-15
LRAC13003	130A	0.3mH	128	64 29	8.4 213	10.8 274	7.25 184	Bus Bar	LRENC-15
LRAC130ACB2	130A	0.17mH	150	57 26	9.5 241	10.24 260	8.18 208	Bus Bar	LRENC-15
LRAC130BCB	130A	0.085mH	117	33 15	8.5 216	9.88 251	4.75 121	Bus Bar	LRENC-15
LRAC16002	160A	0.15mH	149	50 22	8.4 213	10.8 274	6 152	Bus Bar	LRENC-15
LRAC16003	160A	0.23mH	138	67 30	8.4 213	10.8 274	7.13 181	Bus Bar	LRENC-15
LRAC160ACB2	160A	0.13mH	300	55 25	9.5 241	10.24 260	8.18 208	Bus Bar	LRENC-15
LRAC160BCB	160A	0.069mH	127	47 21	9.5 241	10.56 268	8.25 210	Bus Bar	LRENC-15
LRAC20003	200A	0.185mH	146	100 45	10.5 267	10.8 274	9.35 237	Bus Bar	LRENC-20S
LRAC200ACB	200A	0.11mH	340	67 30	9.5 241	11.24 260	8.58 218	Bus Bar	LRENC-15
LRAC25003	250A	0.15mH	219	140 63	14 356	14.4 366	11.35 288	Bus Bar	LRENC-20S
LRAC250ACB	250A	0.088mH	261	91 41	12.38 314	13.44 341	9 229	Bus Bar	LRENC-20S
LRAC360ACB	360A	0.061mH	380	98 44	12.38 314	13.44 341	9 229	Bus Bar	LRENC-20S
LRAC32003	320A	0.125mH	351	190 85	14 356	14.4 366	13 330	Bus Bar	LRENC-20S
LRAC40002	400A	0.06mH	333	155 69	14 356	15.5 394	11.5 292	Bus Bar	LRENC-20S
LRAC40003	400A	0.105mH	293	200 90	14 356	15.5 394	14.5 368	Bus Bar	LRENC-20S
LRAC420ACB	420A	0.053mH	400	100 45	12.38 314	13.44 341	9 229	Bus Bar	LRENC-20S
LRAC480ACB	480A	0.046mH	392	110 49	12.38 314	13.44 341	9 229	Bus Bar	LRENC-20S
LRAC50003	500A	0.085mH	422	290 130	14 356	15.5 394	14.75 375	Bus Bar	LRENC-20S
LRAC600ACB	600A	0.037mH	493	151 68	12.38 314	13.44 341	10.25 260	Bus Bar	LRENC-20S
LRAC750ACB	750A	0.029mH	515	283 127	17.25 438	16.94 430	10.25 260	Bus Bar	LRENC-20S
LRAC850ACB	850A	0.026mH	569	290 130	17.25 438	16.94 430	10.25 260	Bus Bar	LRENC-20S
LRAC950ACB	950A	0.023mH	686	295 132	17.25 438	16.94 430	10.25 260	Bus Bar	LRENC-20S

Additional Baldor Products for your Applications

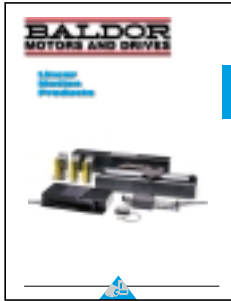

Linear Motion Products
BR1800



Pre-Engineered Control Panels
BR709

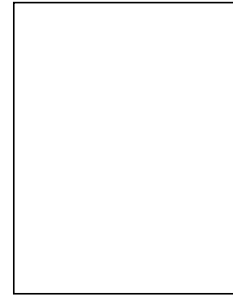

Series 15H Inverter
BR715

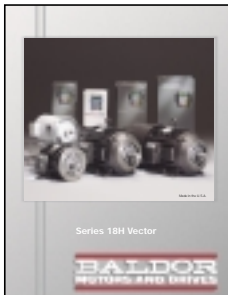

Vector Controls
BR718

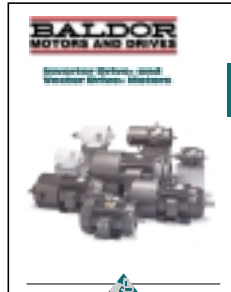

Inverter and Vector Drive Motors
BR400

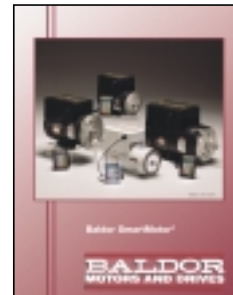

Baldor SmartMotor®
BR750



Bus Capabilities
BR1320

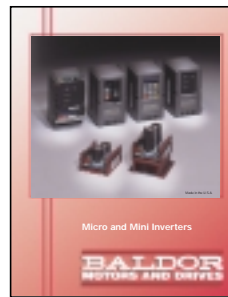

Micro and Mini Inverters
BR781